



DOMINATOR **PLUS**

E3121 Three Hotplate Boiling Top

Key features

- Full depth heavy duty cast iron hotplates
 - Allows multiple cooking positions
- Independently controlled hotplates
 - Use hotplates same way as you would a solid top
- Full width, removable drip tray
 - Easy to remove and keep clean
- Variable, accurate temperature control
 - Ideal for a wide range of menu items
- Laser-etched control icons
 - Permanent, indelible markings

Accessories

- Fixed stand
- Factory fitted, adjustable castors
- Fixed installation kit



Similar Models

- E3121 4HP boiling top
- E3122 2HP boiling top
- E9084 4HP boiling top

Three Hotplate Boiling Top

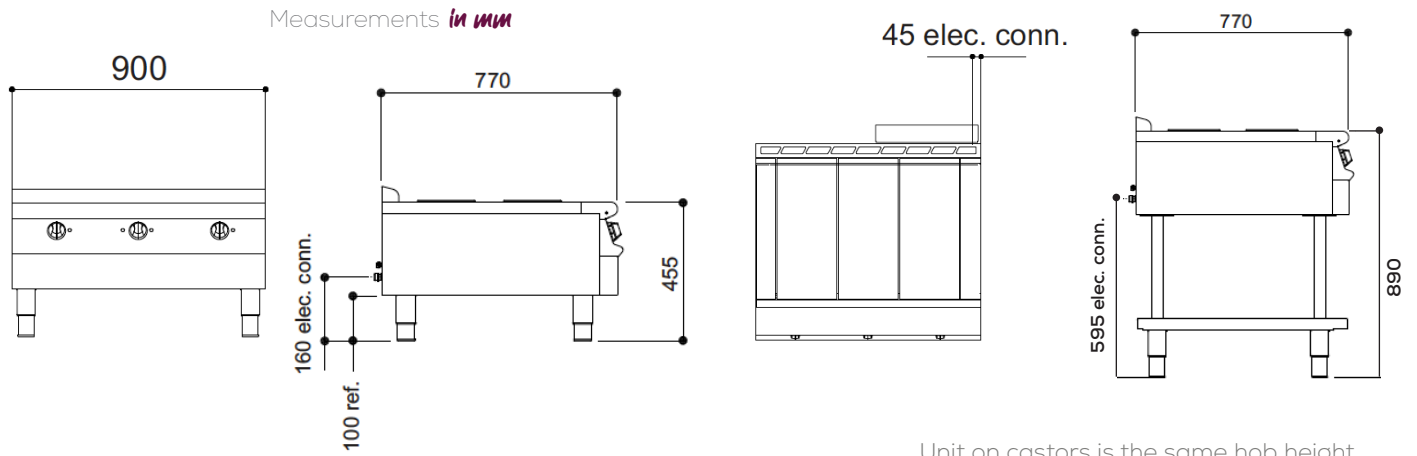

Specification *details*

Electrical rating (kW)	9.6
Electrical supply voltage	400V 3N~
Minimum electrical supply 400V 3N~ (A)	20
Electrical current split (A)	L1: 14 L2: 14 L3: 14
Hotplate rating (kW)	3.2 x 3
Weight (kg)	70
Weight on stand (kg)	100
Packed weight (kg)	83
Packed dimensions (w x d x h - mm)	1000 x 1000 x 600
GTIN number	

Installation notes

Adequate ventilation must be provided to supply sufficient fresh air and to allow easy removal of any such products that may present a risk to health. Please consult current legislation for details that relate to specific locations.

Install unit on a level, fireproof surface in a well-lit position. If floor is made of a combustible material, local fire requirements must be checked to ensure compliance.

A clearance of 150mm should be observed between appliance and any combustible wall.

