



## P0430-2 - Lincat Electric Counter-top Pizza Oven - Twin-Deck - W 966 mm - 8.4 kW

Transport yourself to the Centro Storico district of Naples with the authentic taste of the pizzas from the Lincat Twin-Deck Electric Pizza Oven.

- ✓ Ideal for restaurants, pizzerias, takeaways, fast food outlets, canteens and leisure establishments
- ✓ Perfect for deep pan, thin crust, fresh dough, part baked or frozen pizzas, as well as a variety of other foods such as ciabatta, naan, garlic bread, lasagna, jacket potatoes, pies, pasties and pastries
- ✓ Internal illumination for better visibility of product and enhanced appearance in front of house applications
- ✓ Firebrick base for crisp, even cooking of pizza bases and a maximum temperature of 400°C
- ✓ Independent controls for each deck. Independently controlled top and base of oven compartment for each deck
- ✓ Thermostatic control and temperature display gauge to monitor oven temperature more accurately
- ✓ Double-glazed door construction for energy efficiency with toughened glass for safety
- ✓ 20 minute audible timer

### Specifications

#### Summary

<b>Brand</b>	Lincat
<b>Range</b>	Specialist
<b>Power Type</b>	Electric
<b>Unit Type</b>	Counter-top
<b>Available in UK Only</b>	No
<b>UK Warranty</b>	2 Years Parts and Labour Warranty
<b>Export Warranty</b>	Contact your local dealer
<b>GTIN</b>	5056105103707

#### Power and Performance

<b>Total Power kW</b>	8.4
<b>Temperature Range °C</b>	80-480
<b>IP Rating</b>	IP23
<b>Temperature Control</b>	Mechanical
<b>Oven Rating kW</b>	8.4

#### Key Specifications

<b>Number of Decks</b>	2
------------------------	---

#### Capacity

<b>Pizza Capacity</b>	96 x 12" [30cm] thin crust pizzas [chilled]
-----------------------	---

#### Weights and Dimensions

<b>Unit Height (External) mm</b>	665
<b>Unit Width (External) mm</b>	966
<b>Unit Depth (External) mm</b>	925
<b>Height (Internal) mm</b>	2 x 160
<b>Width (Internal) mm</b>	2 x 630
<b>Depth (Internal) mm</b>	2 x 640
<b>Net Weight Kg</b>	150.4

#### Supply Connections

<b>Requires Installation</b>	Yes
<b>Requires Electrical Supply</b>	Yes
<b>UK 3 Pin Plug</b>	No
<b>Requires Hardwiring</b>	Yes
<b>Electrical Supply Rating Watts</b>	8,400
<b>Single Phase Amps</b>	36.6
<b>Single Phase Voltage</b>	230
<b>Three Phase Amps</b>	L1=12.2; L2=12.2; L3=12.2
<b>Three Phase Voltage</b>	400

#### Shipping

<b>Packed Weight Kg</b>	155
<b>Packed Height cm</b>	96
<b>Packed Width cm</b>	110
<b>Packed Depth cm</b>	97

### Available Accessories

PO430/FS

PO430 FLOORSTAND

**Technical Picture**

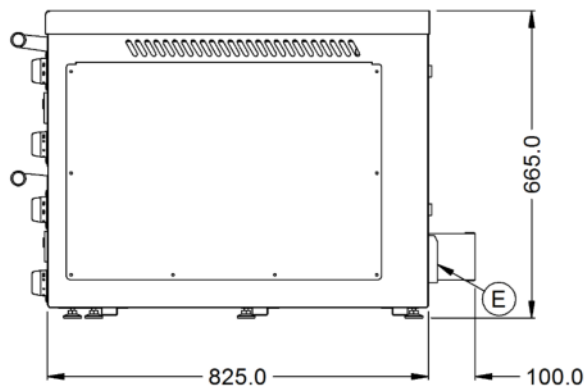
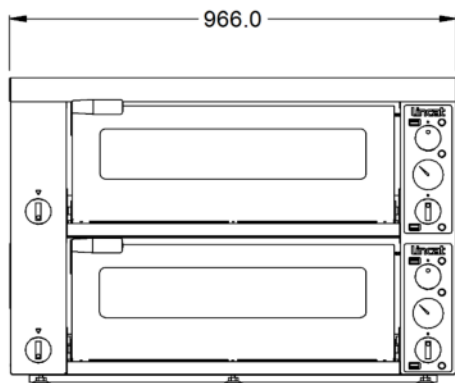
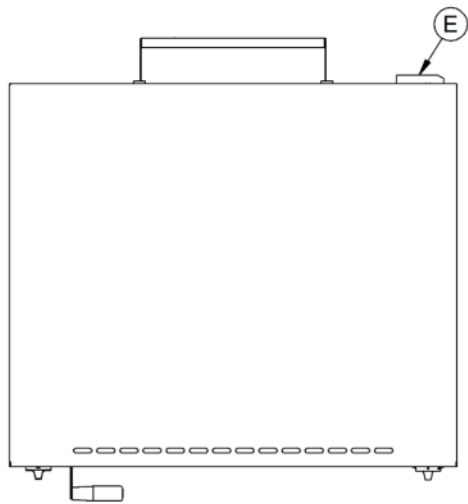

**Lincat Limited**

Whisby Road,  
Lincoln, LN6 3QZ,  
United Kingdom

**Company No:** 2175448

A member company of



**Customer Care**

**Tel:** +44 1522 875500  
**Email:** care@lincat.co.uk

**Export Customers**

**Tel:** +44 1522 503250  
**Email:** export@lincat.co.uk

**Opening Hours**

**Monday – Friday:**  
8.30am – 5pm