



**Model**

MP30

**Product Description**

Planetary Mixer, 30 litre, Heavy Duty

**Product Code**

5MP30-1PH

5MP30-3PH

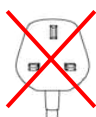

**Standard Features**

- Heavy duty 30ltr, floor standing, gear driven, planetary mixer
- Particularly suitable for bakeries, hotels, restaurants, canteens etc
- Easy to operate
- Planetary mixing action ensures perfect results
- High torque motor allows mixing of stiffer doughs and larger batches
- 3 fixed speeds: 125, 232 and 423 rpm
- Easy speed-shifting
- Timer
- Emergency stop button
- Interlocking bowl guard and bowl lift
- Dual bowl clamps to lock bowl down
- Stainless steel safety guard with ingredient chute and automatic shut-off when guard is opened at any speed
- Resettable thermal overload protection (NVR device)
- Long lasting lubricant providing abrasion resistant transmission
- Transmission gears are made of heat treated, hardened steel
- Heavy duty, cast iron frame
- Non-slip rubber feet
- Quiet operation
- Heavy duty gearbox
- Industry standard #12 attachment hub

**Standard Accessories / Attachments**

- 1 x Whisk
- 1 x Beater
- 1 x Dough Hook
- 1 x 30 litre Stainless steel bowl

**Warranty**

Covered by Metcalfe 3-year warranty (1<sup>st</sup> year parts and labour, 2<sup>nd</sup> & 3<sup>rd</sup> years parts only) and full after sales service

**Optional Attachments**

Item	Product Code
Veg Prep Attachment (no plates included)	MPVS12A

Item	Product Code
Meat Mincer Attachment (6mm & 8mm plates included)	MPG12SH

## Optional Accessories

Item	Product Code
Bowl	MP11031-12-001
Beater	MP11031-12-002
Dough Hook	MP11031-12-003
Whisk	MP11031-12-004
Bowl Trolley	MP11031-12-005

Item	Product Code
20ltr reduction bowl	MP11031-12-001M
20ltr reduction beater	MP11031-12-002M
20ltr reduction dough hook	MP11031-12-003M
20ltr reduction whisk	MP11031-12-004M

## Drawing

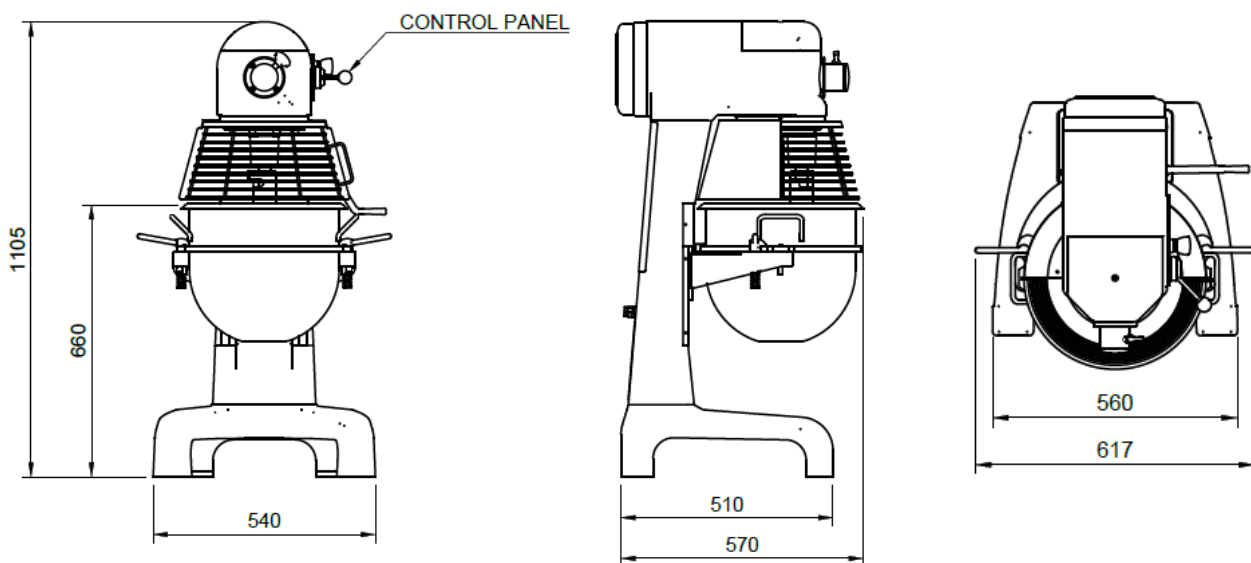

## Specifications

Model	Capacity (ltr)	Phase (Ø)	Motor (Volt)	Frequency (Hz)	AMP (A)	Power (kW / hp)	Speed (rpm)
MP30 – 1ph	30	1	220-240	50	8	0.75 / 1	125 / 232 / 423
MP30 – 3ph	30	3	380-415	50	1.9 total	0.75 / 1	125 / 232 / 423

## Dimensions | Shipping Information

Model	Overall Dimensions D x W x H (mm)	Net Weight (kg)	Packed Dimensions D x W x H (mm)	Packed Weight (kg)	Volume (m3)
MP30	570 x 617 x 1105	185	700 x 600 x 1280	197	0.538

We reserve the right to alter the specification and technical details for this item at any time without prior notice. 12/2021

## Metcalfe Catering Equipment Ltd

Haygarth Park  
Blaenau Ffestiniog  
Gwynedd, LL41 3PF

