



solo per professionisti

Sirman Spa
 Viale dell'Industria 9/11
 35010 PIEVE DI CURTAROLO (PD), Italy
 Tel./Fax. +39 049 9698666 / +39 049 9698688
 email: info@sirman.com



Sirman Slicers , model Palladio 300 :

- Rounded design, no sharp edges and visible screws.
- Chrome plated and ground slide rod.
- Lapped cast iron slide rod bushing.
- Vulcanized rubber stops on carriage.
- Removable support cover for thickness gauge plate.
- Stainless steel slice deflector with bayonet fitting.
- Stainless steel screws and fittings.
- Enclosed and sealed belt pulley.
- 49,5 mm distance between blade and motor.
- Bottom cover.
- Changeover electronic circuit 110-220-380 V single and three phase.
- Built in sharpening tool with bottom protection.
- Standard blade removal tool.
- 35° blade inclination
- Plastic knob.
- Buttons in insulated stainless steel (IP 67) in housing.

Optional Stonehenge:

- Cast aluminum alloy with special ceramic-teflon coating treatment
- Ideal for sticky products processing
- Excellent product gliding and easy to clean
- Highly resistant to acids and sanitizing chemicals
- Removable parts are dishwasher safe
- Aluminum-gray finish colour.

Available versions:

- **Stonehenge:** table, blade cover, carriage, end weight
- **Stonehenge Plus:** base, table, knife rim guard, blade cover, carriage, end weight, sharpener housing



Large hopper

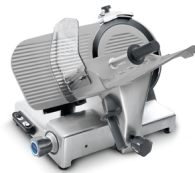

Palladio Stonehenge

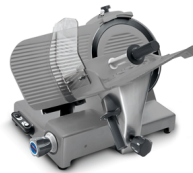

Palladio Stonehenge Plus



Data sheet

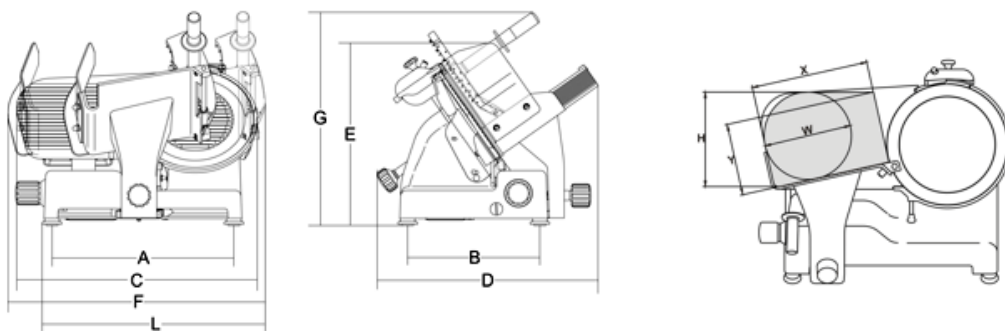

Technical data

Model	PALLADIO 300
ø Blade	mm 300 - inch. 12
Motor	watt 275 - Hp 0,37
Cut thickness	mm 23
Run of carriage	mm 310
Hopper	mm 305x270
A	mm 465
B	mm 340
C	mm 615
D	mm 547

E	mm 465
F	mm 710
G	mm 545
L	mm 600
X	mm 270
Y	mm 190
H	mm 240
W	mm 220
Net weight	kg 35
Shipping	mm 760x640x700
Gross weight	kg 44
HS-CODE	84385000